



Tripod Turnstile manual book



MODEL:
JS-SGZ003B

Chapter 1 – Products specification

1.1 Products Introduction:

SGZ003B tripod turnstiles is a popular choice when checking tickets at sports stadiums, amusement parks, and other place which need pay to entry , The information will be synchronized to the management center, where you can view the real-time entry and exit data, set the validity period of tickets, and count the monthly, quarterly, and annual revenues. You can also connect with your own cloud platform and payment system, support card swiping, QR code or other access method you prefer, and the 7-inch LCD can set the display content according to customer requirements

1.2 Application Location:

SGZ003B is a robust tripod turnstile perfect for crowd control at ticketed events. The built-in ticket box can accept a variety of credential types . Indoor and Outdoor models available. All of its features make it perfect pedestrian entrance solution for concert venues, parks, outdoor events, sports fields, and numerous other environments.

1.3 Dimension drawing:

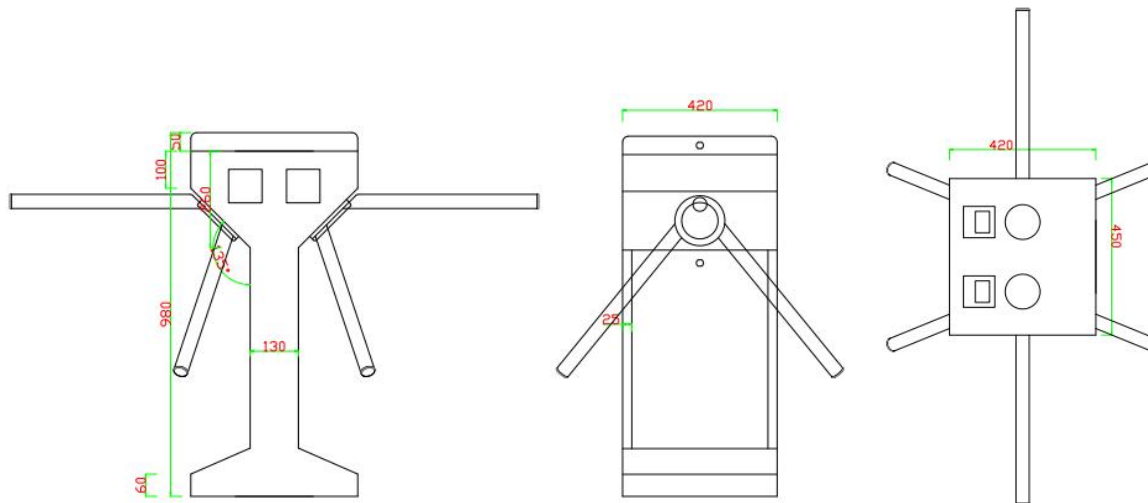

1.4 Specification:

Power Supply	AC 220V/110V, 50/60Hz
Operating Temperature	-28 °C– 80 °C
Operating Humidity	5%–85%
Working Environment	Indoor / Outdoor both, IP54 Standard
Rated Power	60W
Flow Rate	25– 48 passage/minute
Casework Material	SUS304 (SUS 316 for option)
Mechanism	Semi automatic electromagnetic mechanism with hydraulic buffer function (full automatic brushless motor for option)
Control System	Dry contact
Emergency Alarm function	Yes
Dimension	420*450*980MM + arm length 500MM
Net Weight	38kgs
Material Thickness	1.5mm
MCBF	Electromagnetic mechanism 5 million cycles , brushless motor 8 million cycles
Warranty	2 years

Chapter 2 – INSTALLATION

Before proceeding to the installation of the turnstile, unpack all components and check to make sure the all parts from the packing slip are included, verify dimensions and conduit runs.

Use the turnstile template to properly align and lay out the site and to determine the right location of the floor stub-ups and anchors.

Site preparation:

- Make sure that the floor is level before the installation process starts.
- When measuring the distance between the cabinets always refer to the center of the cabinets, not the corners.
- Using the factory provided template and design layout drawings outline the exact position of each turnstile. Make sure the floor outline includes the space dedicated to conduit stub-ups.
- Install conduits for low voltage cables and for 110Vac (220Vac) power. Size conduits based on the number of cables and follow local installation codes.
- Install one ¾ inch conduit for turnstile communication between two cabinets that form one lane.
- Depending on the position, each enclosure can host one or two motors. The end cabinets have only one motor (SM series) and the middle cabinets have two motors (DM series).
- Each controller operates one motor. SM series have one controller and DM series have two controllers.
- On the turnstile floor footprint, locate anchoring holes. Drill and install foundation screw bolts or M12 anchor bolts.
- Align and install the turnstile cabinet on the anchor bolts. Secure the cabinet to the bolts.
- Follow wiring diagram to terminate the cables on the turnstile control panel. The following

connections are required:

- Card reader to control panel reader port. The control panel can be located inside the turnstile or outside.
- Communication cable between cabinets.
- Lane OPEN command from the turnstile to the access control panel door open relay.
- If required, an emergency open button or switch can be wired to the turnstile controller board.
- 110Vac (220Vac) is required for each turnstile cabinet.

- For physical installation setup refer to the next drawing.

Installation Design

- ◆ Place the turnstiles in the correct direction and combination.
- ◆ After connecting the power and testing the basic functions are normal, turn off the power and place the turnstile in the entrance where it needs to be installed.
- ◆ Mark the drilling position, punch hole to fix the gate.
- ◆ After set holes, drilled holes, and embedded M12 anchor bolts or expansion bolts.

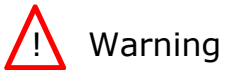
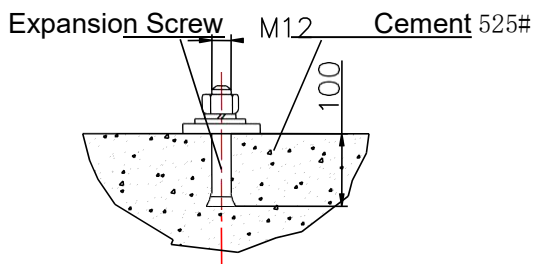

Warning

1. The depth of buried PVC pipes should be greater than 60mm, and the height of exposed ground should be greater than 50mm. And the outlet is bent back to prevent water from entering the line pipe
2. When installing access gates, the left and right gates of each channel should be aligned;
3. Connect the system protection ground wire;
4. If the equipment is used outdoors, a 100~200mm high cement level should be built at the equipment installation place. Tailai to isolate moisture, and add sunscreen and rainproof facilities such as roof;

After the equipment is installed, the state inspection and functional debugging are qualified before it can be put into normal use.

Chapter 3 – cable connecting

3.1 control system

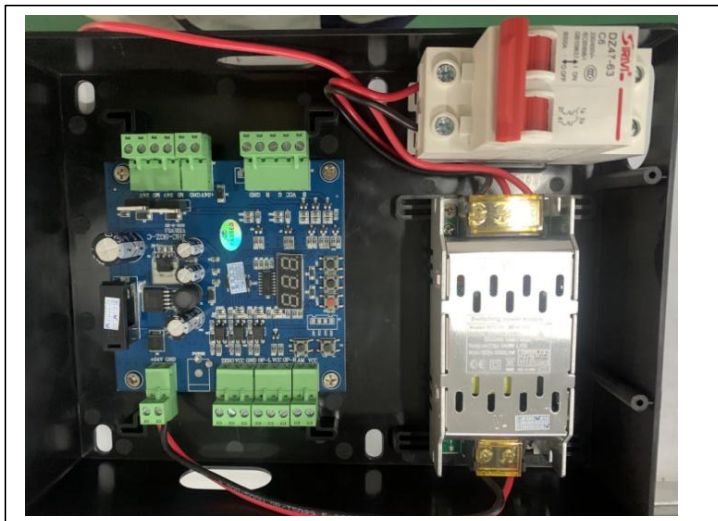

3.2 Relay signal for your access control system

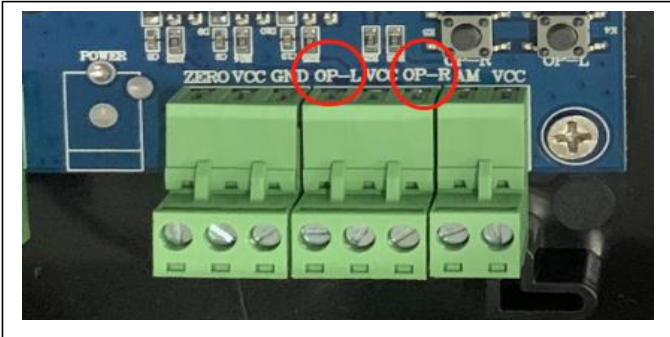

3.3 220V power to air switch



Chapter 4 – main board setting

type C control board parameter description V 2.0

mainboard V 2.0

三辊闸主板V2.0

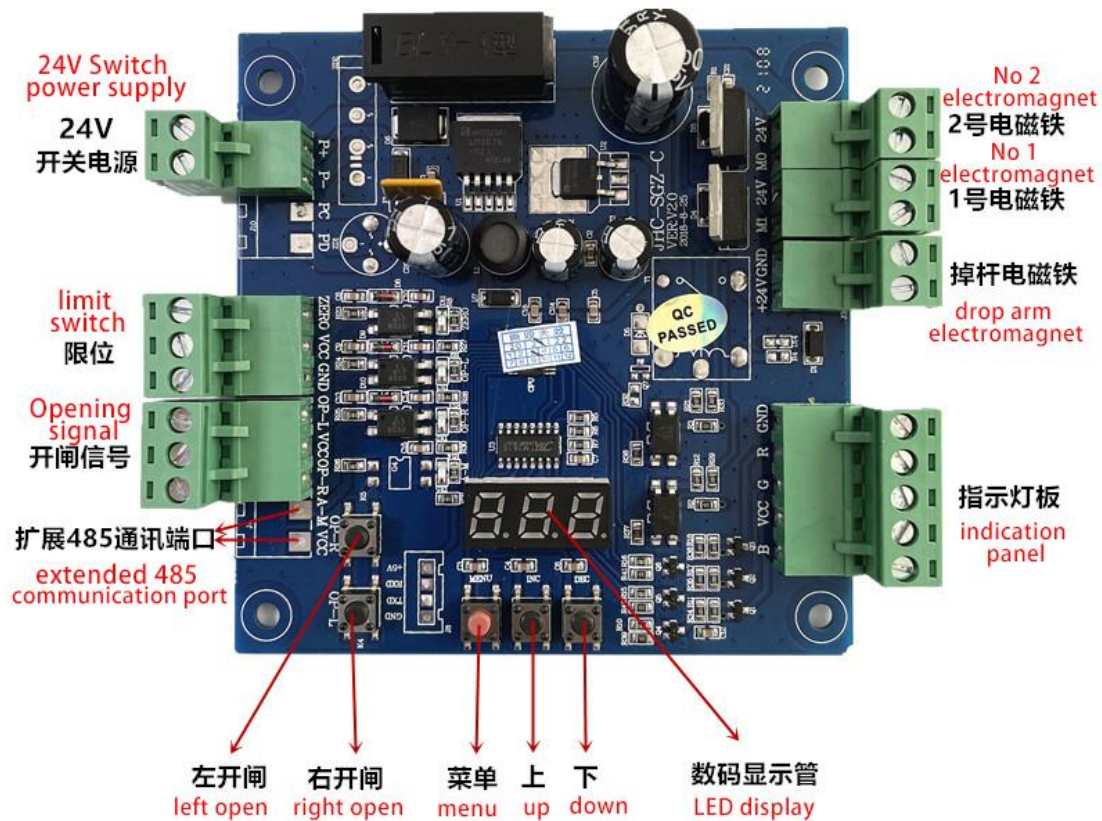

Menu setting description

Control panel keys: " **MENU** " menu key, " **INC** " up/up key, " **DEC** " down/down key three operation keys.

Function description of each function key:

" **MENU** " key: 1: Long press this key in the standby interface to enter the system menu: 2: In the system menu interface, select the corresponding menu and press this key to enter the menu parameter setting interface: 3: Press this after the menu is set key to save the parameters and return to the system menu interface.

" **INC** " key: turn up to select the system menu and the function of +1 when setting parameters

" **DEC** " key: scroll down to select the system menu and the function of -1 when setting parameters

NOTE: In the system menu and menu setting interface, if there is no key operation within 5 seconds, the system will automatically exit the menu to the standby interface.

For example, to change the access duration of the gate passage :

Step 1: Long press the " MENU " key to enter the system menu, and use the " INC " and " DEC " keys to scroll up and down respectively to select the " F01 " menu (see the menu description below).

Step 2: Press the " MENU " key to enter the channel duration setting interface.

Step 3: Use the " INC " and " DEC " keys to add and subtract parameter values up and down respectively.

Step 4: After the setting is completed, press the " MENU " key to save.

parameter setting description:

Function	menu	set range	Defaults	Parameter Description
Set the passage time	F01	240	5	Within the set time, the time will be automatically cleared after the person passes the gate. If no one passes, the gate will automatically close when the time is up. (The system defaults to 5 seconds)
Allow and forbid passage	F02	0/1 /2 /3	1	0: All left and right openings are prohibited. 1: All are allowed. 2: Left opening is prohibited, right opening is allowed. 3: Right opening is prohibited, left opening is allowed. (All are allowed by default)
Gate operating mode	F03	0/1	1	0: Free passage (commonly used on turnstiles) 1: Power-off drop bar (default power-off drop bar)
memory function	F04	0/1	0	Whether there is a memory function when opening or closing the entrance and exit, it is generally used for swiping a card to open the gate, whether to remember the card swiping situation of other people when one person has not

				passed the card swiping. "Prohibited" means that after the first person swiping the card is passed , the second person swiping the card will be valid; "Allow" means that the number of people who swipe the card is how many consecutive people are allowed to pass. (disabled by default)
Repeated opening and closing test	F05			Mainly used to test the stability and aging test of the gate control board. C-5 : In test mode, press MENU key to exit the test
Zero work setting	F06	0/1	0	0: Standard mode, 1: Reset mode after the zero signal is disconnected. (The motherboard defaults to 0);
Proximity switch count reset setting	F07	1-30	1	The default setting of the motherboard is 1 , and it will sense a reset , and so on.
485 Xun Xun IP address settings	F09	1-99	1	The motherboard defaults to an IP address of 0 1 . For example, there are two machines that need the computer to send action commands. In order not to interfere with each other, the other machine can be set to the IP address of 02.

reset	F10			All parameters of the motherboard are restored to factory settings. Display --- then press MENU to confirm and exit.
-------	-----	--	--	--

RS485 communication protocol

Baud rate: 96 00 parity bit N, data bit 8, stop bit 1

The factory default of the communication address bit is 01

Factory default:

AA 55 01 (communication address bits can be set) F3 01 is left open

AA 55 01 (communication address bit can be set) F3 0 5 is stop

AA 55 01 (communication address bit can be set) F3 0 3 is the right opening

AA 55 01 (communication address bit can be set) F3 0 7 is the fire signal opening

AA 55 01 (communication address bit can be set) F3 0 A is the host reset

To operate the left open gate, send the command: AA 55 01 F3 01

Chapter 5 – Safety attentions

- Do not strike the product with hard objects.
- Handle carefully when using to avoid strong collision with hard objects.
- The product must not be exposed to water or corrosive liquids.
- If smoke or odor is found in the product, disconnect the power immediately.
- If the product is abnormal, please contact the dealer in time. Do not attempt to repair it by yourself. If you do not contact the dealer, handle it without permission, and the company will not be responsible for any damage.

Chapter 6 – Transportation and storage

- Handle the product with care when handling it.
- During the transportation and storage of the product, care should be taken in a dry and free of corrosive or explosive gas in the surrounding air, and measures should be taken to prevent moisture, rain, sun, and corrosion

Thank you for your support, we are very happy to be your partner and provide you with our services. If you encounter any problems during the installation, you can contact your service manager at any time. We will serve you wholeheartedly ,ENJOY!

----- KARSUN TEAM