



## Classic Sliding Turnstile Model:JS-PYZ003



### General Information:

Karsun sliding speed gates provide aesthetic and effective control of entry or exit at kinds of toll collection systems like train/metro stations, and access control for commercial centers, stadiums, schools, government and private sector buildings etc.

This classic sliding turnstile PYZ003 features an elegant design, high speed, high security, small noise operation, smooth running, and a long life span. It's highly integrated to be compatible with face recognition temperature scanner, fingerprints access control, QR system, ESD access control RFID, etc. Designed for heavy traffic sites with smooth and silent operation. They eliminate the need for attendants at entrances and provide a means to count the number of pedestrians entering into a facility. These turnstiles paired with card readers and electronic operation are the most popular choice for subway systems and can be found in most of them.

### Access Control System (Optional)



**SWIPE CARD**  
Access with authorized card and payment card swipe to open the gate



**IRIS RECOGNITION**  
Use the authorized eyes of Iris Recognition to pass through the entry gates



**FINGERPRINT RECOGNITION**  
Access with authorized fingerprint authentication



**PALM VEIN RECOGNITION**  
Use authorized palm vein recognition to pass into



**COIN/TICKET**  
Use disposable coins to enter



**FACE RECOGNITION**  
Use authorized face recognition to enter



**QR CODE**  
Scan in with authorization QR code and barcode



**MANUAL OPERATION**  
Manual use of wired and wireless to open gates for entry

# Features



### Appearance

- High end appearance,
- Main body and lateral lids are AISI 304-grade stainless steel.
- Top lid:Black acrylic panel
- Flap panel:Acrylic/tempered,10mm thickness
- IR sensor:6 pairs(can be customized)



### Drive technology

- Brushless servo motor ensures the longer lifespan and smooth and durable running
- Self developed mainboard,ARM controltech
- Famound brand electrical components



### Safety and User-Orientated Design

- 1.2/1.5/1.8m high retractable glass door for strict access control.
- Precise and durable mechanisms for mass traffic application sites.
- Humanized indicator lights and voice prompts



- Anti-follow
- Anti-climb/creep
- Anti-panic
- Anti-pinch

### Easy Integration

- Defaulted with card swiping window covered with black acrylic panel.
- Wide compatible to various recognition methods available

Communication interface:Relay signal.  
Standard electrical interface for third party device.

- KARSUN provides not only turnstile system but also complete solutions for our customers,for instance,online/offline ticketing/ attendance /visitor management/EU green pass and etc.



# Measurement:

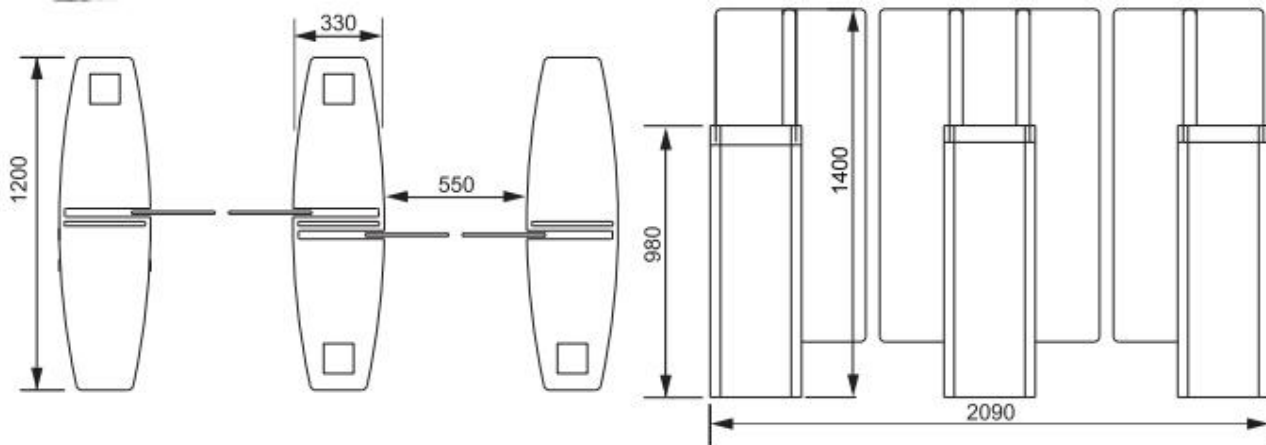

<b>Brand name</b>	KARSUN
<b>Mechanism part</b>	Connecting rod structure
<b>Motor type</b>	DC brushless motor/Servo motor
<b>Flow rate</b>	30-40people/minute
<b>Passage width(mm)</b>	650-900
<b>Rated Power</b>	80W
<b>Cabint material</b>	SUS 304/316 ; 1.5mm thickness
<b>Infrared sensor</b>	6 pairs
<b>Door height(mm_</b>	800/1000/1200/1500/1800
<b>Input/Output signal</b>	dry contact/relay signal
<b>Dimension</b>	1600*300*1000mm
<b>IR sensor(pair)</b>	6 (defaulted)
<b>Net weight</b>	68KG
<b>Gross weight</b>	73KG
<b>IP</b>	IP44
<b>Operating Temperature</b>	-28 °C- 60 °C
<b>Operating Humidity</b>	5%-85%
<b>Working Environment</b>	Indoor/Outdoor covered
<b>Voice prompt</b>	Yes