

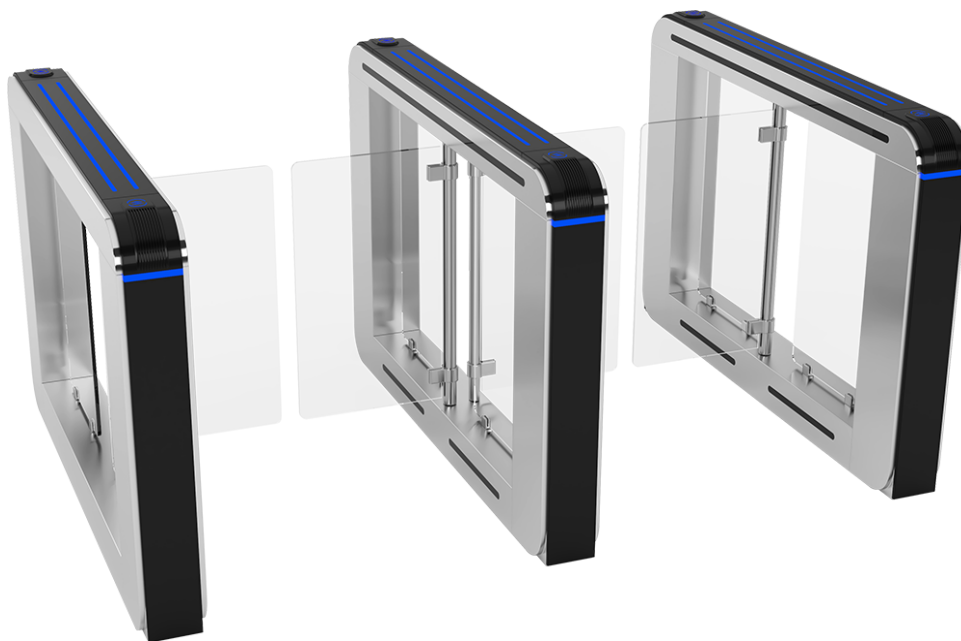

Luxury swing gate manual book



MODEL:
JSTD9162-21

Dimension drawing

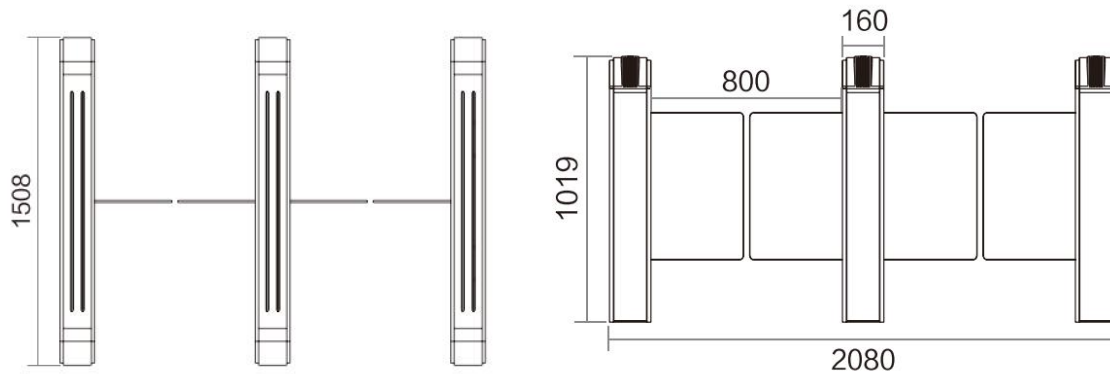

Chapter 1 – Products specification

1.1. Product specifications

The **JSTD9162-21** high speed turnstiles have the following characteristics:

- Power requirements: 110V -220V, 250W to 500W. The swing turnstiles are provided with different power supplies, based on country and customer's requirements. Check the product label before connecting to any power supply.
- Driver motor: 24Vdc, max. 40W
- Output interface: 12Vdc
- Communication interface: Relay, (RS232, RS485 for option, can be customize)
- Operating temperature: 14°F to 122°F [-10°C to 50°C]
- Operating humidity: 20% to 95% RH non-condensing

Chapter 2 – INSTALLATION

Before proceeding to the installation of the turnstile, unpack all components and check to make sure the all parts from the packing slip are included, verify dimensions and conduit runs.

Use the turnstile template to properly align and lay out the site and to determine the right location of the floorstub-ups and anchors.

Site preparation:

- Make sure that the floor is level before the installation process starts.
- When measuring the distance between the cabinets always refer to the center of the cabinets, not the corners.
- Using the factory provided template and design layout drawings outline the exact position of each turnstile. Make sure the floor outline includes the space dedicated to conduit stub-ups.
- Install conduits for low voltage cables and for 110Vac (220Vac) power. Size conduits based on the number of cables and follow local installation codes.
- Install one ¾ inch conduit for turnstile communication between two cabinets that form one lane.
- Depending on the position, each enclosure can host one or two motors. The end cabinets have only one motor (SM series) and the middle cabinets have two motors (DM series).
- Each controller operates one motor. SM series have one controller and DM series have two controllers.
- On the turnstile floor footprint, locate anchoring holes. Drill and install foundation screw bolts or M12 anchor bolts.
- Align and install the turnstile cabinet on the anchor bolts. Secure the cabinet to the bolts.
- Follow wiring diagram to terminate the cables on the turnstile control panel. The following connections are required:
 - Card reader to control panel reader port. The control panel can be located inside the turnstile or outside.
 - Communication cable between cabinets.
 - Lane OPEN command from the turnstile to the access control panel door open relay.
 - If required, an emergency open button or switch can be wired to the turnstile controller board.
 - 110Vac (220Vac) is required for each turnstile cabinet.
- For physical installation setup refer to the next drawing.

Installation Design

- ◆ Place the turnstiles in the correct direction and combination.
- ◆ After connecting the power and testing the basic functions are normal, turn off the power and place the turnstile in the entrance where it needs to be installed.
- ◆ Mark the drilling position, punch hole to fix the gate.
- ◆ After set holes, drilled holes, and embedded M12 anchor bolts or expansion bolts.

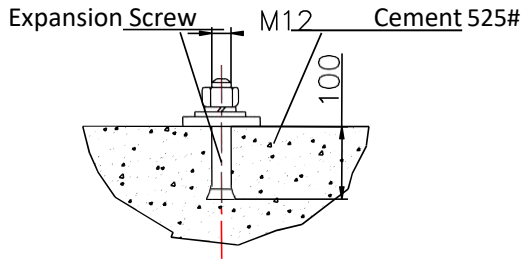

Warning

1. The depth of buried PVC pipes should be greater than 60mm, and the height of exposed ground should be greater than 50mm. And the outlet is bent back to prevent water from entering the line pipe
2. When installing access gates, the left and right gates of each channel should be aligned;
3. Connect the system protection ground wire;
4. If the equipment is used outdoors, a 100~200mm high cement level should be built at the equipment installation place. Tailai to isolate moisture, and add sunscreen and rainproof facilities such as roof;
5. After the equipment is installed, the state inspection and functional debugging are qualified before it can be put into normal use.

Chapter 3 – cable connecting

synchronous line connection direction

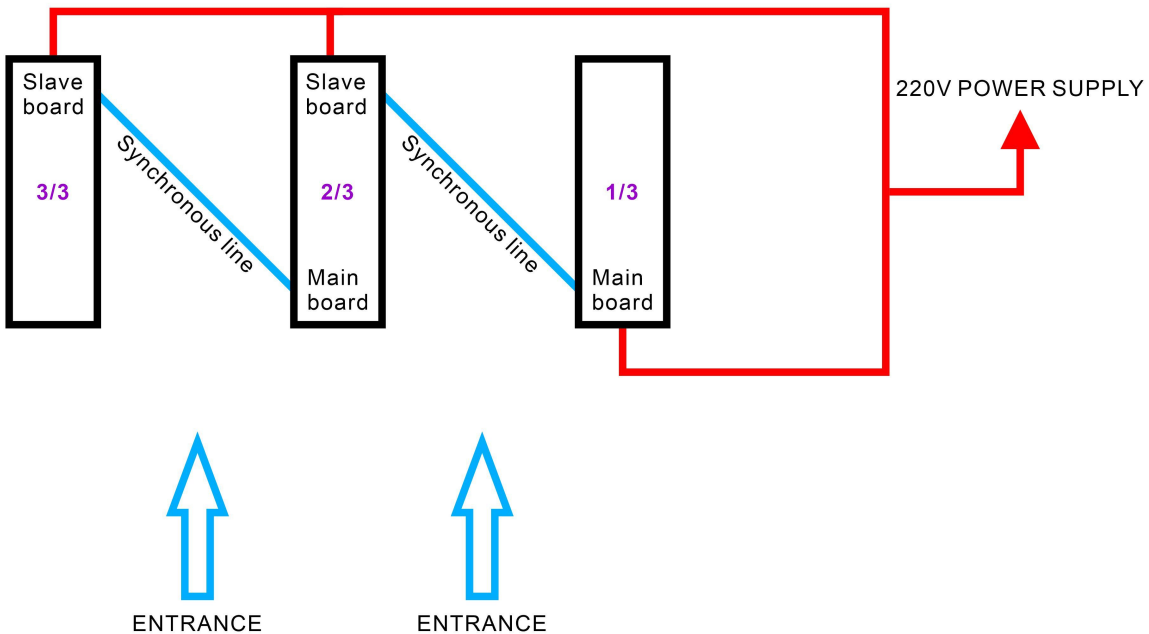

Chapter 4 – Main board setting

MBC2405C channel gate controller, equipped with brushless servo motor, servo control technology, real-time detection of motor position, no external encoder, self-learning load curve, with physical anti-clip protection, sensitivity adjustable characteristics; Support access mode Settings such as card swiping, free and prohibited; It has the logic detection of illegal entry, following passage, retention reverse passage, infrared anti-clamp and so on. It is suitable for various kinds of channel gates, swing gates, wing gates, translation gate three roller gate and so on.

Functional characteristics

	MBC2405C brushless servo scheme	Ordinary brushless scheme
Adaptation motor	2400 line position feedback brushless motor	Ordinary BRUSHless DC motor
The clip protection	Current + position dual detection, sensitivity adjustable	Low sensitivity without encoder to prevent clamping
Control effect	Fast opening and closing speed, stable in place, no shaking	No position encoder in place stop instability

Technical parameters

- ◇ Input power: DC24V, recommend a unilateral 150W / 6.5A;
- ◇ Adaptation motor: Brushless DC motor below 60W with 2400 line position feedback;
- ◇ Communication mode: RS232 serial port communication, Modbus protocol is supported;
- ◇ Spare battery: DC12V (for switching off power);
- ◇ Working environment: -20°C ~ 55°C, humidity below 90% (no condensation);
- ◇ Infrared sensor: 6 independent interfaces, PNP or NPN normally open, collector open type;
- ◇ Audio output: external 8w 4 Ω horn.

Normal open and fire protection functions

- **Normally open mode:** Long press the card button 3 seconds or the GND level 3 seconds of the swiping signal port, and the switch will enter the normal opening mode. At this time, the access door opens (infrared judgment fails), the light shows green light, and the buzzer and horn have no output. Cancel the signal, switch off the door, and restore the previous state.
- **Fire protection mode:** Auxiliary port F is connected to GND, and the gate enters the fire-fighting mode. At this time, the door opens (infrared judgment fails), the light shows green light, the buzzer rings, and the voice announces "fire alarm, please evacuate quickly". Cancel the GND level, switch the gate and restore the previous state.

Port definitions

Master machine port

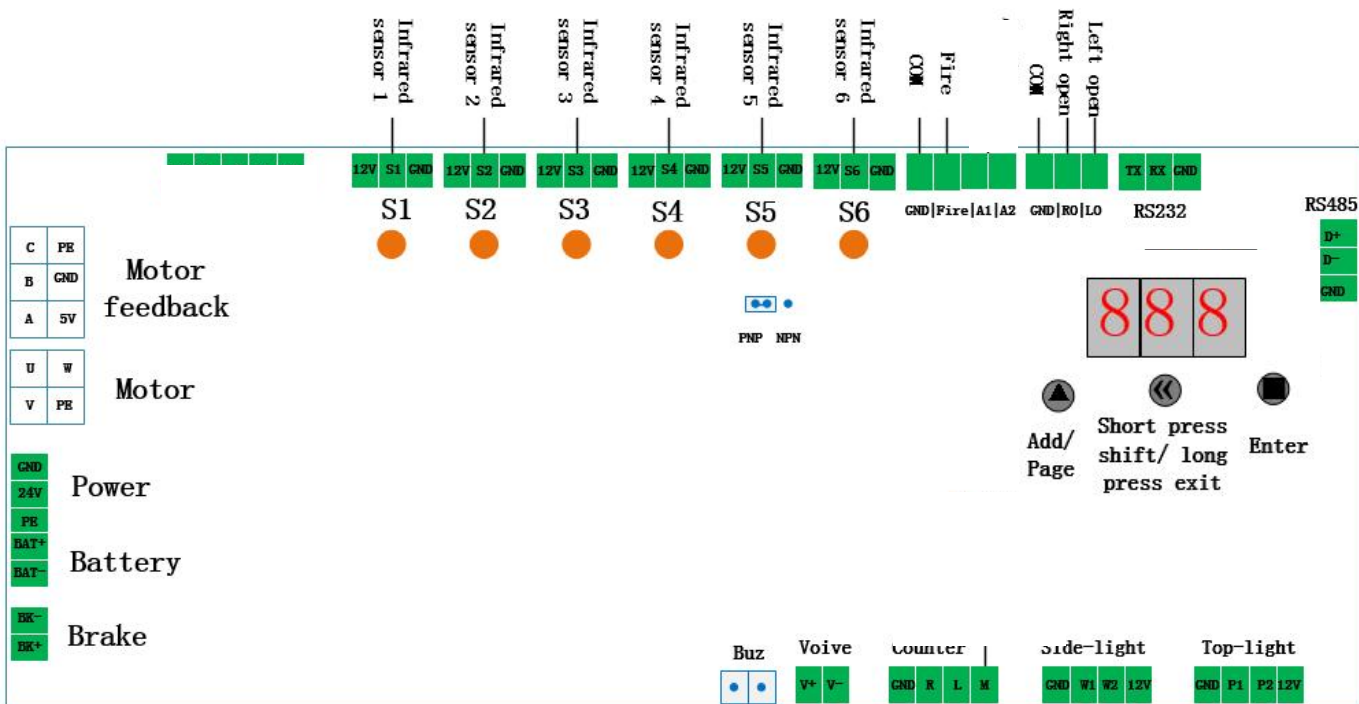

Slave machine port

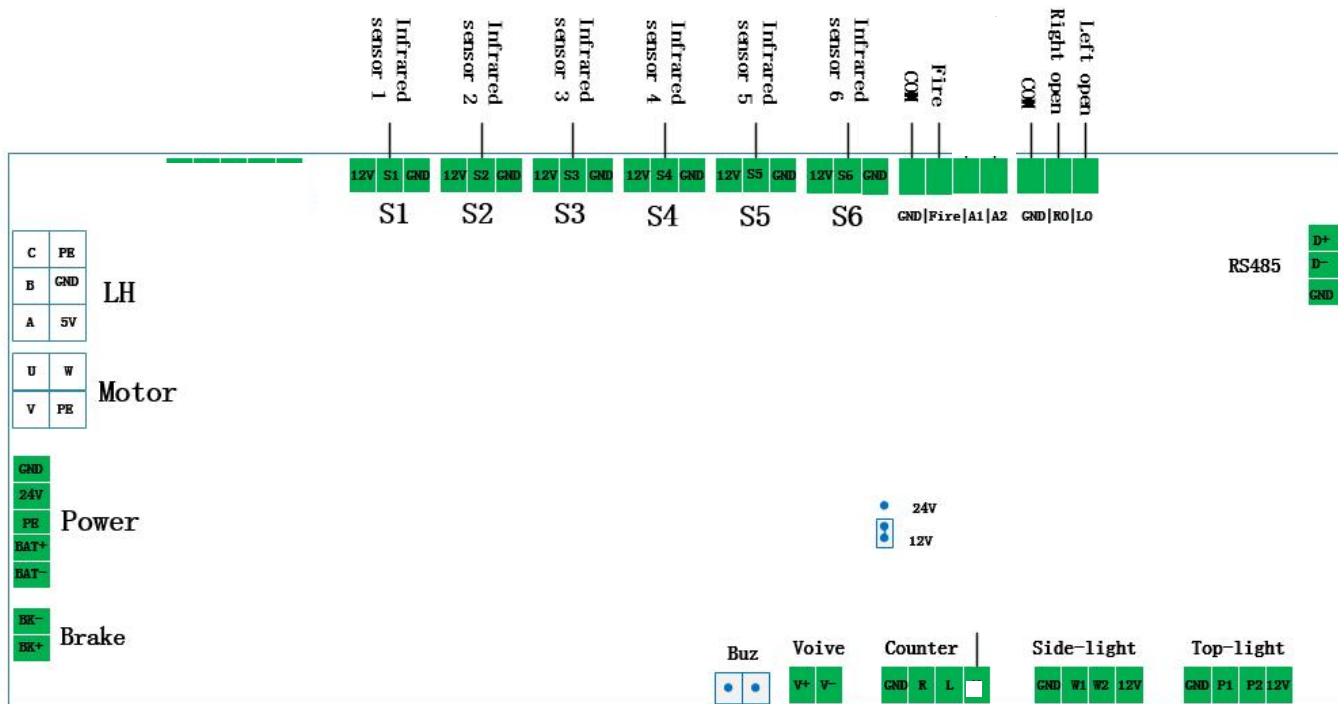

Ports and Instructions

BAT-	External 12 v 1.3 Ah battery, without breaking function can not meet when power supply drop	PE	Motor feedback 6Pin socket
BAT+			
GND	Used for external auxiliary incremental encoder	A	
A		B	
B		C	
Z		5V	
5V		GND	
		PE	

Input port:

12V	The infrared signal is connected to ports S1~S6. 3 groups of infrared layout can only connect S1 ~ S3, 4 groups of infrared layout can only connect S1 ~ S4, 6 groups of infrared layout can only connect S1 ~ S6.	GND	Signal common end
S1~S6		LO	The entrance direction opens the door for input signal
GND		RO	The exit direction opens the door for input signal
GND	Signal common end	A1	
Fire	Fire function input signal		

Output port:

BK+	Directly connected with the clutch, there is no need to distinguish positive and negative	B+	Connect active buzzer horn
BK-		B-	
V+	Voice horn, the recommended specifications: 8 w 4 Ω	L	GND is the common end of the counter; L is the count output of the inlet pass direction; R is the count output of the inlet pass direction;
V-		R	
M	Alarm signal output, three rollers brake electromagnet output; 12V/24V output can be selected by jumper cap	GND	
12V	Pass light/Top-light, which supports signal panel by default, P1 and P2 are respectively the green light control output ports of entrance and exit (high level).	12V	Welcome light/side-light, which supports signal panel by default. W1 and W2 are respectively the green control output ports of the entrance and exit (high level).
P1		W1	
P2		W2	
GND		GND	

Communication port:

TX	RS232 communication port, can communicate with the upper computer, pay attention to TX and RX connection need to cross	D+	RS485 communication port as master and slave synchronous connection; The slave can only communicate with the host computer or the upper computer via RS485
RX		D-	
GND		GND	

Set the operating

Keys operation

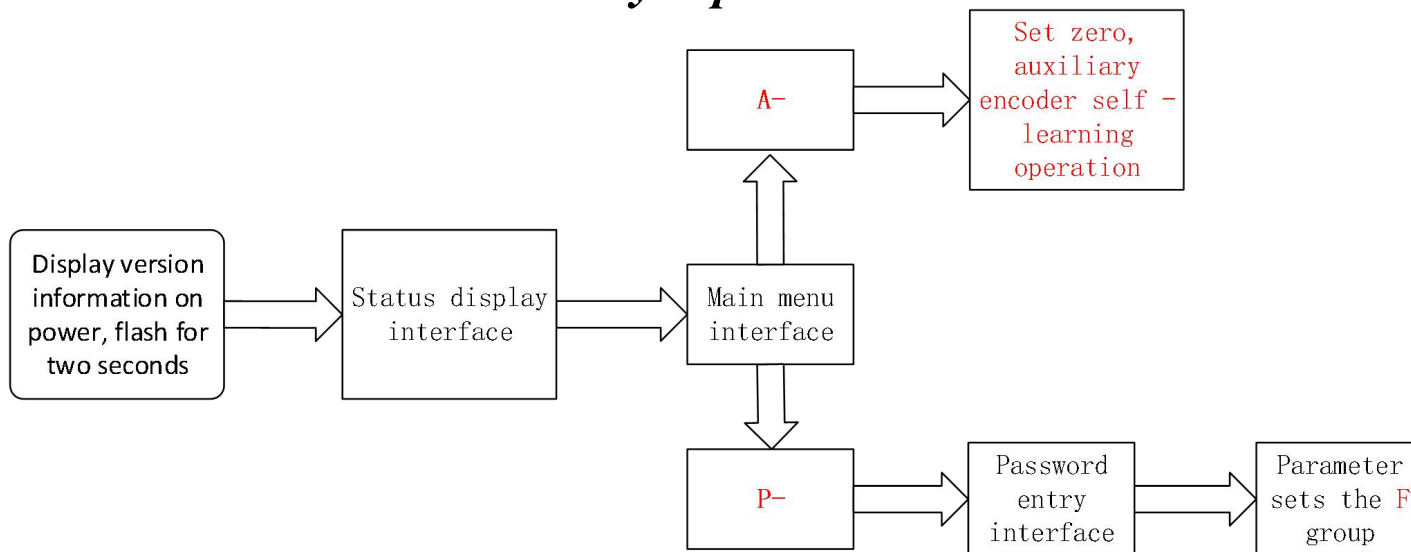

1. 1. Key Function



Menu display

A- menu	
Display code	function
SE0	Set zero point
roP	Right opening
CLo	close a door
LoP	Zuokai
rSt	reset

Set the zero point (A-SE0)

Step 1: Exit to the main menu and find the parameter setting menu entry "A-", then press "■" on the right to enter the submenu, and press "▲" on the left to find "SE0"; Or enter "000" on the password entry screen.

Step 2: Again short press the right "■" confirm, the door into the disabled state, then put the door to the set position.

Step 3: After 5 seconds, the switch will reset automatically.

2. Quick debugging wizard

Express gate/swing gate/wing gate/translation gate:

step	name	operate	remarks
1	Set master-slave machine	Set F00 master 000, slave 001 Set the rotation direction of F01 motor to 0/1	
2	Set gate type	Set F33 selection 0- swing gate double door 2- wing gate double door	The swing gate is set to 0, the wing gate and the translation door are set to 2; Power on again after setting.
3	Set motor reduction ratio	Set F49 parameters according to actual reduction ratio.	The structure of the movement with speed reduction ratio needs to be set.
4	Set infrared type	Set infrared PNP/NPN jumper cap Set F37 0-PNP /1-NPN type	0-PNP default value
5	Set infrared logarithm	Set F17 to select 3 pairs, 4 pairs or 6 pairs.	The default value is 1-6 for infrared
6	Set zero point	A-SE0 sets the zero position of door panel	Only the swing brake needs to be set to zero point.
7	Set the switch position	Set F14 and F15 parameters	F14 is reverse opening/closing.
8	Setting switch speed	Set F03 motor speed percentage	

3. Parameter list

Operation password

Password	Function	Password	Function
211	Debugging permission	111	Query infrared status
618	Reset	321	Restore the default value

Parameter setting

NO.	Function code addresses	Function code name	default	Setting range	remarks
F00	05 01	Master-slave machine setting	0	0 ~ 1	0- Master 1- Slave
F01	00 0D	Rotation direction of motor	0-0	0 ~ 1	0-0 (slave-master) 0- reverse 1- forward rotation
F02	04 08	reserve	0	0 ~ 3	reserve
F03	09 00	Switch speed (%)	60	1 ~ 100	Percentage of rated motor speed
F04	09 01	acceleration	20	1 ~ 200	The higher the value, the faster the acceleration.
F05	09 06	Running blocking current	1.0	0 ~ 900	0 means no blocking judgment. The smaller the value, the higher the anti-pinch sensitivity.

NO.	Function code addresses	Function code name	default	Setting range	remarks
F06	09 08	Looking for zero-turn blocking current	2.5	1 ~ 100	Increase appropriately when looking for zero abnormality.
F07	09 09	Velocity loop ratio	120	1 ~ 999	When the door panel is heavy, increase it appropriately.
F08	09 0B	Position ring ratio	45	1 ~ 999	Appropriately reduce the overshoot in position.
F09	08 1D	Push judgment angle strongly	2.5	1 ~ 90.0	The larger the setting value, the larger the pushing angle.
F10	08 09	Zero change speed	10	1 ~ 80	Percentage of rated motor speed
F11	08 25	Blocking mode selection	1	1 ~ 2	1- rebound at an angle 2- Reduced speed and torque
F12	08 18	Push mode selection	1	0 ~ 1	0- unlock clutch 1- lock clutch
F13	08 10	Emergency stop mode	1	0 ~ 1	0- unlock clutch 1- lock clutch
F14	0A 19	Closed indentation angle	5.0	1 ~ 90.0	The smaller the setting value, the larger the opening and closing angle (corresponding to swing: reverse opening angle and wing brake: closing angle)
F15	0A 1A	Open-in-place indentation angle	5.0	1 ~ 90.0	The smaller the setting value, the larger the opening angle (corresponding swing gate: positive opening angle, wing gate: opening angle)
F16	0F 00	Gate mode	1	0 ~ 10	0: Aging mode 1. Two-way credit card swiping 2. Two-way freedom 3. Two-way prohibition 4: Forward swipe+Outbound freedom 5: Forward swipe card+Outbound prohibition 6: Forward freedom+outward swipe 7. Forward freedom+outward prohibition 8. Forward prohibition+outward freedom 9: Incoming prohibition+Outgoing credit card swiping 10: Test mode (no access logic)
F17	0F 01	Infrared logarithm	1	0 ~ 2	0:3 to infrared 1:6 to infrared 2:4 to infrared
F18	0F 02	Continuous swipe card	0	0 ~ 1	0: invalid 1: valid
F19	0F 03	Gate standby state	0	0 ~ 1	0: normally closed 1: normally open
F20	0F 04	Maximum transit time	10	1~ 65	Unit: seconds, automatic closing after timeout.
F21	0F 05	In-channel swipe card	1	0 ~ 1	0: disallowed 1: allowed
F22	0F 06	Is the door closed retrograde?	1	0 ~ 3	0: Don't close the door 1: Close the door 2. Don't close the door after the reverse entry, and switch to the standby state after the passage is

NO.	Function code addresses	Function code name	default	Setting range	remarks
					completed. 3. Turn back the door, and switch to the standby state after the back-up is cancelled.
F23	0F 07	Voice volume	15	0 ~ 15	
F24	0F 08	Trailing detection delay time	30	0 ~ 999	Unit: 10 ms
F25	0F 09	Do you lock the clutch when the door is in place?	0	0 ~ 1	0: do not lock 1: lock
F26	0F 0A	Whether illegal intrusion locks the clutch or not.	0	0 ~ 1	0: do not lock 1: lock
F27	0F 0B	Infrared filtering time	1	0 ~ 500	Unit: 10 ms
F28	0F 0C	Allow the opposite credit card delay time after credit card swiping	500	0 ~ 600	Unit: 10 ms
F29	0F 0D	Fire direction	1	0 ~ 1	0: Open the door outward 1: Open the door inward
F30	0F 0E	Post-swipe opening delay	0	0 ~ 500	Unit: 10 ms
F31	0F 0F	Post-closing delay of traffic	0	0 ~ 500	Unit: 10 ms
F32	0F 10	Maximum residence time in channel	10	0 ~ 999	Unit: second
F33	0F 12	Type of controller (Power on again after modification)	0	0 ~ 3	0: Swing double doors 1. Swing single door 2. Wing brake double doors 3. Wing brake single door
F34	0F 14	Trigger anti-pinch delay	32	0 ~ 999	Unit: 1ms
F35	0F 15	Exit anti-pinch delay	250	0 ~ 999	Unit: 1ms
F36	0F 16	Gate control command	0	0 ~ 32	1: positive open 2: reverse open 16: forward normally open 32: reverse normally open (decimal unit)
F37	0F 17	Infrared type	0	0 ~ 1	0:PNP normally open 1:NPN normally open
F38	0F 18	Open the door with or without buzzer.	0	0 ~ 1	0: None 1: Yes
F39	0F 19	Chinese and English pronunciation	0	0 ~ 1	0: Chinese 1: English
F40	0F 1A	Entrance voice setting (welcome)	0	0 ~ 79	Define and query the Voice Content Table specifically.
F41	0F 1B	Exit voice setting (bon voyage)	6	0 ~ 79	
F42	0F 1C	Trailing voice setting (please pay attention to trailing traffic)	3	0 ~ 79	
F43	0F 1D	Reverse voice setting (reverse entry, please exit and wait)	2	0 ~ 79	
F44	0F 1E	Detention voice setting (do not stay as soon as possible)	4	0 ~ 79	
F45	0F 28	Gate breaking voice (illegal breaking, please verify and pass)	1	0 ~ 79	
F46	0F 29	RGB lamp output enable	2	0 ~ 2	0: Disabled (traffic lights and welcome lights are valid) 1: bidirectional RGB lamp logic 2. Standard RGB lamp logic
F47	05 04	Baud rate setting (RS232)	5	0 ~ 5	4800 / 9600 / 19200 / 38400 / 57600 / 115200

NO.	Function code addresses	Function code name	default	Setting range	remarks
F48	08 14	Blocking rebound angle	20.0	0 ~ 99.9	The higher the setting value, the larger the Big bounce angle.
F49	08 00	reduction ratio	25	1 ~ 999	Actual reduction ratio setting
F50	0F 2A	Counter output mode	0	0 ~ 1	0- Default counter output 1- output as traffic light 2- Output as welcome light
F51	05 0D	Synchronization interface setting	0	0~1	0-RS485 1-RS232
F52	09 03	reserve	60	1~100	reserve
F53	09 0C	reserve	3.0	0~300	reserve
F54	08 0B	reserve	15.0	1~90.0	reserve
F55	08 22	reserve	20	10~300	reserve
F56	0A 0C	reserve	3	0~9	reserve
F57	0C 0C	reserve	251	1~999	reserve
F58	06 07	reserve	100	0~ 900	reserve
F59	00 0E	reserve	20	1~ 200	reserve
F60	0F 2F	Process triggered anti-pinch infrared selection	1	0~ 1	0- Don't open the door (emergency stop) 1: Open the door
F61	04 06	Selection of motor model	4	1~4	1: MBS59R-60S-2020 2: MBS80F-60A-3018 3: MBS57R-60A-2026 4: MBS70F-40A-1825
F62	0F 30	Security check signal effective time setting	5	0~65	Unit: second
F63	0F 34	reserve	0	0~90	reserve
F64	0F 35	reserve	0	0~90	reserve
F65	08 1F	Loose clutch time	200	0~900	Unit 0.1ms

Speech Content Table

By setting F39 (Chinese and English speech) parameters, the speech playing language type can be switched. The f40-F45 parameters can be set to voice content as needed.

Setting code	Chinese content	Setting code	English content
0	欢迎光临	80	Welcome
1	非法闯入请验证后通过	81	Do not enter, authorized personnel only
2	反向进入请退出等候	82	Unauthorized access from opposite direction
3	尾随通行请注意	83	Don't follow
4	尽快通行请勿逗留	84	Please pass through quickly
5	逆行通过请注意	85	Passing from opposite direction
6	一路平安	86	Have a nice trip

Setting code	Chinese content	Setting code	English content
7	自检过程异常	87	Initialization failure
8	主从机通讯异常	88	Communication error
9	无	89	无
10	无	90	无
11	消防报警, 请迅速撤离	91	Fire warning, please evacuate immediately
12	无	92	Master controller
13	无	93	Slave controller
14	欢迎再次光临	94	Welcome again
15	欢迎回家	95	Welcome home
16	多谢惠顾	96	Thank you for your patronage
17	您已进入监管区域	97	You are under surveillance
18	进入施工现场, 请戴好安全帽	98	Construction area! Hard hats must be worn
19	当前仅限一人通行	99	Only one passenger allowed at one time
20	请验证后通过	100	Authorized personnel only
21	通道关闭	101	Closed off
22	请在黄线外刷卡或验票	102	Please authorize outside the line
23	电压过高	103	The voltage is too high
24	电压过低	104	The voltage is too low
25	出口红外故障	105	Exit infrared fault
26	入口红外故障	106	Inlet infrared fault
27	防夹红外故障	107	Anti pinch infrared fault
28	系统初始化	108	System startup
29	验证失败	109	Verification failure
30	请小心通行	110	Please be careful
31	上电找零失败	111	Failed to search for zeros
32	欢迎入校	112	Welcome to enter
33	请进	113	Please come in
34	请刷脸通行	114	Please brush your face to pass

State diagnosis

Gate state

For example, "A08" means that the master gate is closed and in place; "S08" means that the slave gate is closed and in place.

Satus code	Satus information	Satus code	Satus information
------------	-------------------	------------	-------------------

00	Motor disability	10	Stop and pushing
01	Looking for zero	12	Eergency stop
02	Left opening	13	Master slave wait timeout
03	Right opening	14	Run block of the other side
04	Left closing	15	Stop and pushing of the other side
05	Right closing	17	Zero recognition
06	Left open in place	18	Dive alarm
07	Right open in place	21	Power failure switch on
08	Close in place	22	Power failure switch on finish
09	Run block	23	Reset

Alarm information

Alarm code	Aarm information	Alarm handling method
P01	Break in alarm	Traffic alarm
P02	Stranded alarm	
P03	Anti-rush alarm	
P04	Trailing alarm	
P05	Master slave communication alarm	Check the master-slave connection
E01	Hall is missing	Check the encoder cable or replace the motor
E02	EEPROM error	rive hardware failure or software version exception
E03	Mtor stalling	Check motor load jam or abnormal motor
E10	V - phase current zero correction error	Driver hardware failure
E11	U-phase current zero correction error	
E12	Undervoltage	The bus voltage is too low, check the input power
E13	Overvoltage	The bus voltage is too high, check the input power
E16	Overcurrent	Driver bus overflows, check motor wiring
E18	Find zero failed	1-Check the transmission structure for skid 2-F49 deceleration ratio parameter setting is wrong

Serial communication protocol

MBC2406A series channel controller uses RS232 serial communication port and adopts Modbus communication protocol format. Through serial communication mode, data exchange can be conducted with the channel controller, such as sending door opening instructions, reading the status of the channel gate, setting relevant parameter values, etc.

Serial port type	RS232
Baud rate	115200
Check bit	Nothing
Stop bit	1

1	2	3	4	5	6	7	8
ID	CMD	ADDR_H	ADDR_L	DATA_H	DATA_L	CRC_L	CRC_H
DestID	Command key	Function code address		Data-high	Data-low	CRC Check low	CRC Check high

DestID

Master controller is **0x01**, slave controller is **0x02**;

Command key

Read function code command is **0x03**, write function code command is **0x06**;

Function code address

Function code address is **0C 00**, address is **0x0C 0x00**;

Date

Function code value **01**, the data is **0x00 0x01**;

CRC check

CRC16 check value, **CRC_L CRC_H**;

Open the door instruction

The data bit high position is the number of swipes, in which **00** and **01** are single swipes.

The data bit low position is selected for the opening direction, **01** represents the left-open to the authorization, **02** represents the right-open to the authorization.

Single authorization to open the door command

Command	Send	Return
Left open	01 06 0F 16 00 01 AA DA	09 08 00 01 00 01 71 43
Right open	01 06 0F 16 00 02 EA DB	09 08 00 02 00 01 81 43

Multiple authorization to open the door command

Command	Send	Return
6 passes in a row Entrance direction open	01 06 0F 16 06 01 A9 7A	09 08 00 01 00 06 CRC_L CRC_H
12 passes in a row Exit direction open	01 06 0F 16 0C 02 EF DB	09 08 00 02 00 0C CRC_L CRC_H

When the continuous swiping card function is invalid (**F18 = 0**), multiple swipe card commands are equivalent to a single swipe card command;

When the continuous swiping card function is effective (**F18= 1**), the function code value **01 01** is equal to **00 01**, which is a single swipe card command;

The traffic completion status is returned automatically

The remaining number of passable times, swipe the card 1 time, the number of times plus 1, the number of pass completed 1 time, the remaining number minus 1

Used to judge the traffic state of channel gate:

When it is displayed as 0, it means that all traffic is completed;

When displayed as **FF FF**, a pass timeout is indicated;

When displayed as **00 XX**, means the remaining **00 XX** passable times.

When the pedestrian's normal passage is completed or the passage is timed out, the controller will automatically return to the passage state and return format:

ID	Return type	Direction of traffic: 0x01 Entrance direction、0x02 Exit direction	The remaining xx times of passability	CRC16 Check
09	04	00 0x	XX XX	CRC L CRC H

Single swipe card

Actual traffic status	Corresponding value	Return instruction content
Haven't entered the channel after swiping my card	00 01: remaining 1 time	Do no return
Traffic completed in entrance direction, normal closing	00 00: traffic completion	09 04 00 01 00 00 CRC_L CRC_H
Traffic completed in exit direction, normal closing	00 00: traffic completion	09 04 00 02 00 00 CRC_L CRC_H
There is timeout for traffic, The channel gate is closed	FF FF: traffic timeout	09 04 00 01 FF FF CRC_L CRC_H

Multiple swipe card

For example: After the continuous swiping card function is opened, when swiping the card for 3 consecutive times in the entrance direction:

Actual traffic status	Corresponding value	Return instruction content
The first person passes, and the gate remains open	00 02: remaining 2 time	09 04 00 01 00 02 CRC_L CRC_H
The second person passes, and the gate remains open	00 01: remaining 1 time	09 04 00 01 00 01 CRC_L CRC_H
The third person passes, normal closed.	00 00: traffic completion	09 04 00 01 00 00 CRC_L CRC_H
If anyone does not timely access to traffic between a timeout, the channel is closed.	FF FF: traffic timeout	09 04 00 01 FF FF CRC_L CRC_H

Illegal traffic alarm query

Command	Send	Return
Traffic status query	01 03 0F 1F 00 01 B6 D8	01 03 02 x1 x2 CRC_L CRC H
❖ The returned x1 x2 are the data values of this function code, and the corresponding data values are as follows: 0: No alarm 1: Break in alarm 2: Stranded alarm 3: Reverse alarm 4: Trailing alarm		

Traffic alarm status will be returned automatically

Actual state of passage	Return instruction content
Normal passage is completed after swiping card	Do not return

Actual state of passage	Return instruction content
Break in alarm	09 05 00 00 00 01 0D 42
Stranded alarm	09 05 00 00 00 02 4D 43
Reverse alarm	09 05 00 00 00 03 8C 83
Trailing alarm	09 05 00 00 00 04 CD 41

Traffic status query

Command	Send	Return
Traffic status query	01 03 0F 20 00 01 86 D4	01 03 02 x1 x2 CRC_L CRC_H
❖ The returned x1 x2 are the data values of this function code, and the corresponding data values are as follows: 0: The system did not start properly 1: Free status 2: Aging status 3: Fire fighting status 4: Entrance direction swipe card status 5: Exit direction swipe card status 6: Set zero status 7: Entrance direction freedom status 8: Exit direction freedom status 9: Power failure switch on status 10: The system is normally open status		

Pass times query

Command	Send	Return
Read the entrance population statistics	01 03 0F 24 00 02 87 14	01 03 04 X1 X2 X3 X4 CRC_L CRC_H
Read the exit population statistics	01 03 0F 26 00 02 26 D4	01 03 04 X1 X2 X3 X4 CRC_L CRC_H
Empty the population statistics	01 06 0F 13 00 01 BA DB	Raw date return

X1 X2 is the high data of population statistics, X3 X4 is the low data of population statistics ;

The entrance population statistics = the high data of population statistics × 65536 + the low data of population statistics;

The exit population statistics = the high data of population statistics × 65536 + the low data of population statistics;

Empty the population statistics: Empty both entrance and exit population statistics.

Switch speed gear (standard version)

instruction	send	return
300 acrylic	01 06 08 0F 00 00 BB A9	Original data return
300	01 06 08 0F 00 01 7A 69	

instruction	send	return
tempered glass		
400 acrylic	01 06 08 0F 00 02 3A 68	
400 tempered glass	01 06 08 0F 00 03 FB A8	
50 acrylic	01 06 08 0F 00 04 BA 6A	
50 tempered glass	01 06 08 0F 00 05 7B AA	
60 acrylic	01 06 08 0F 00 06 3B AB	
00 toughened glass	01 06 08 0F 00 07 FA 6B	

Appendix I. Reference parameters corresponding to different door panels:

Door panel material	Acrylic 300	Tempered glass 300	Acrylic 400	Tempered glass 400	Acrylic 500	Tempered glass 500	Acrylic 600	Tempered glass 600
Door speed (F03)	1200 (60%))	900 (45%))	900 (45%))	800 (40%))	800 (40%))	500 (25%))	700 (35%))	450 (22%))
Acceleration and deceleration (F04)	20	15	15	10	12	10	10	5
Speed ring (F07)	120	180	130	180	200	220	220	320
Position ring (F08)	45	45	38	28	26	16	20	14

Lighting wiring

Welcome lamp board + double pass lamp board

(Set the parameter F46=0)

Welcome light: when idle, green light is allowed to be displayed in the traffic direction, and red light is forbidden; When swiping a card, the main direction is green and the opposite direction is red.

Pass light: red lights when idle; When swiping a card, the main direction is green and the opposite direction is red.

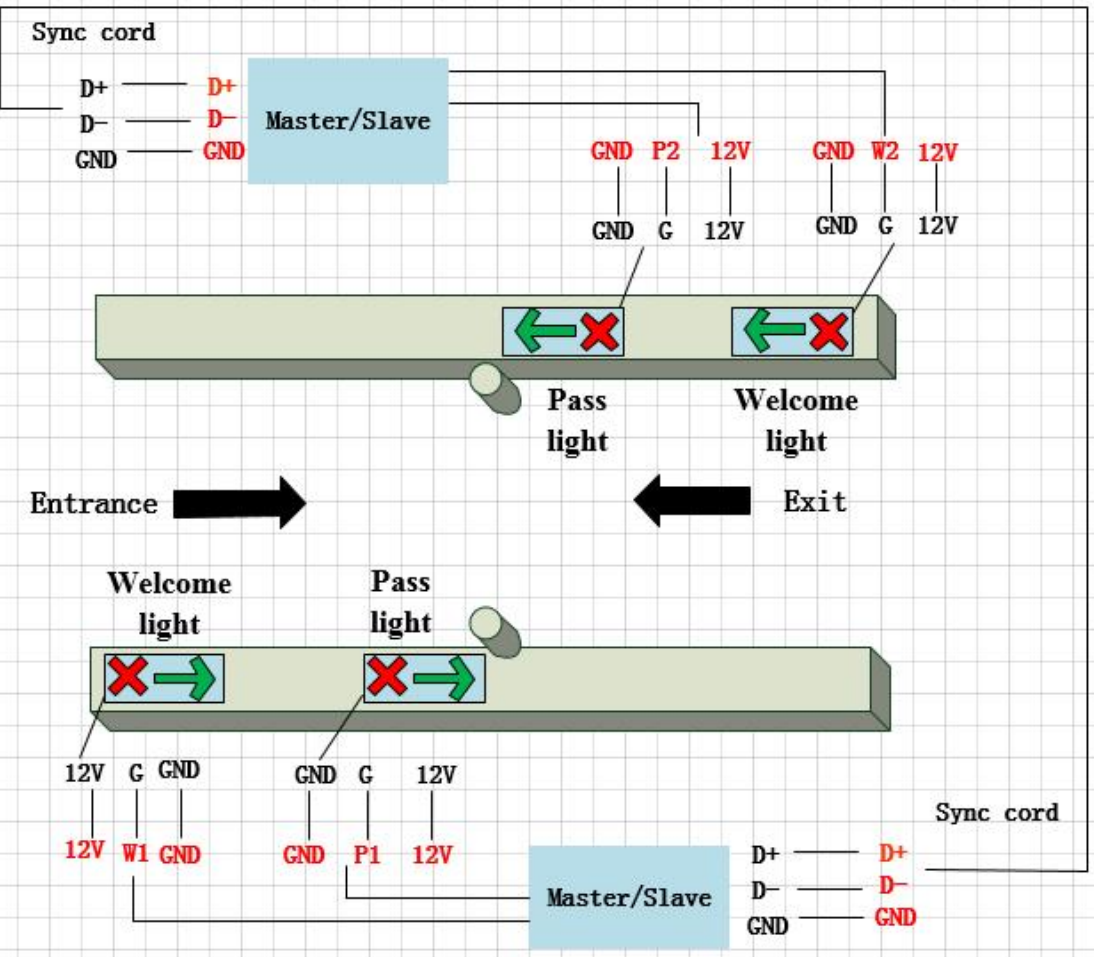

Welcome lamp board + single pass lamp board

(Set the parameter F46=0)

Welcome light: when idle, green light is allowed to be displayed in the traffic direction, and red light is forbidden; When swiping a card, the main direction is green and the opposite direction is red.

Pass light: double arrow green light when idle; When swiping a card, a single arrow indicates the direction of travel.

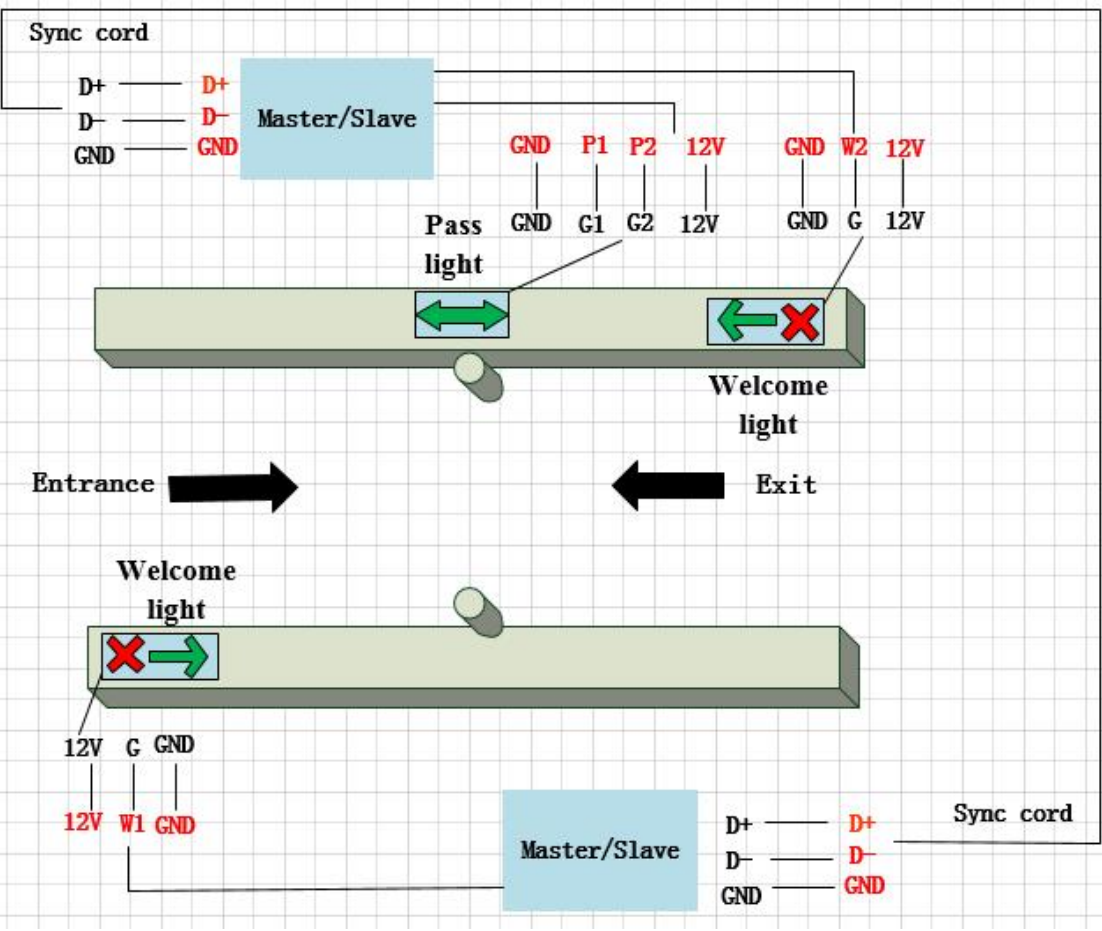

Welcome lamp board +RGB tricolour light

(Set the parameter F46=2)

Welcome light: when idle, green light is allowed to be displayed in the traffic direction, and red light is forbidden; When swiping a card, the main direction is green and the opposite direction is red.

Tricolor light (common anode) : blue light when idle; When swiping the card, the green light is displayed; The red light is displayed when the alarm is raised.

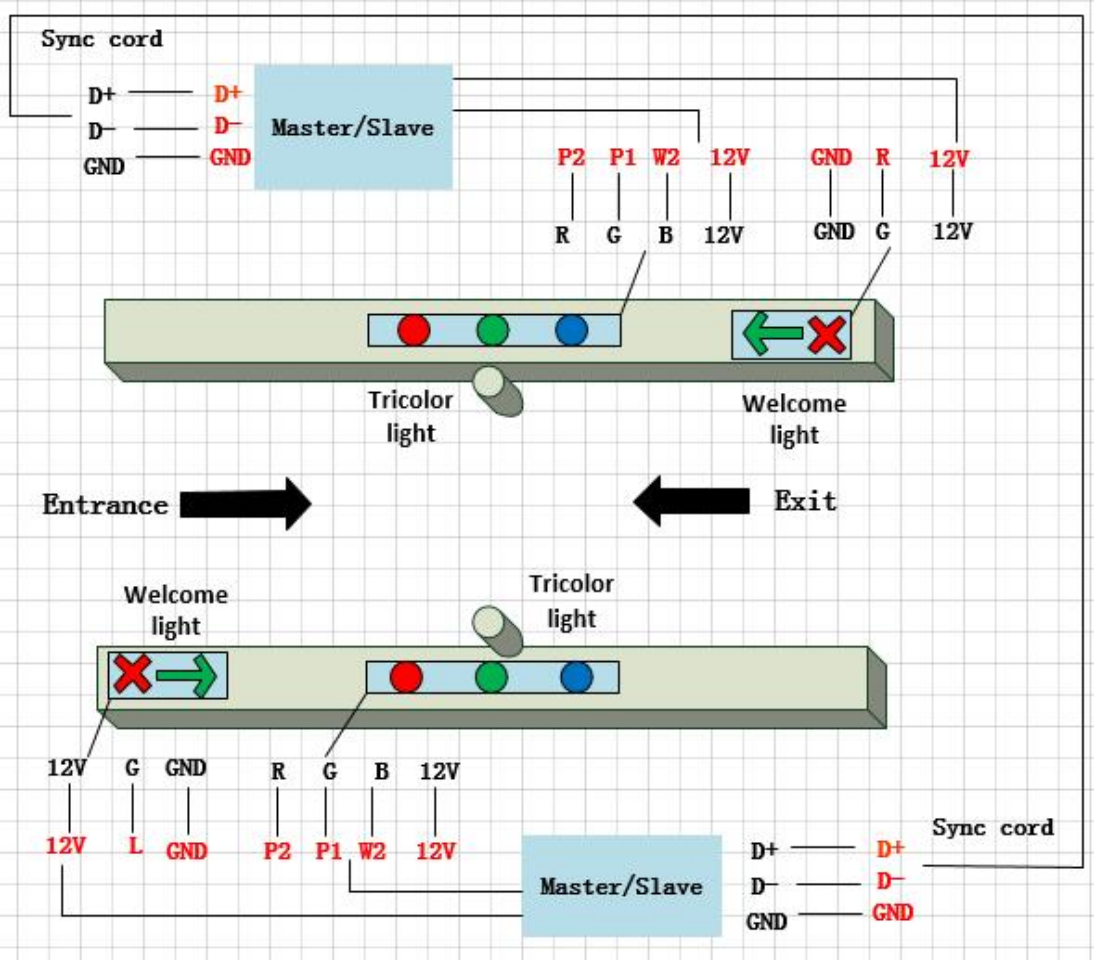

Welcome lamp belt + RGB tricolour light

(Set the parameter F46=2, F50=2)

Welcome light (common anode) : when idle, green light is allowed in the traffic direction and red light is forbidden; When swiping a card, the main direction is green and the opposite direction is red

Tricolor light (common anode) : blue light when idle; When swiping the card, the green light is displayed; The red light is displayed when the alarm is raised.

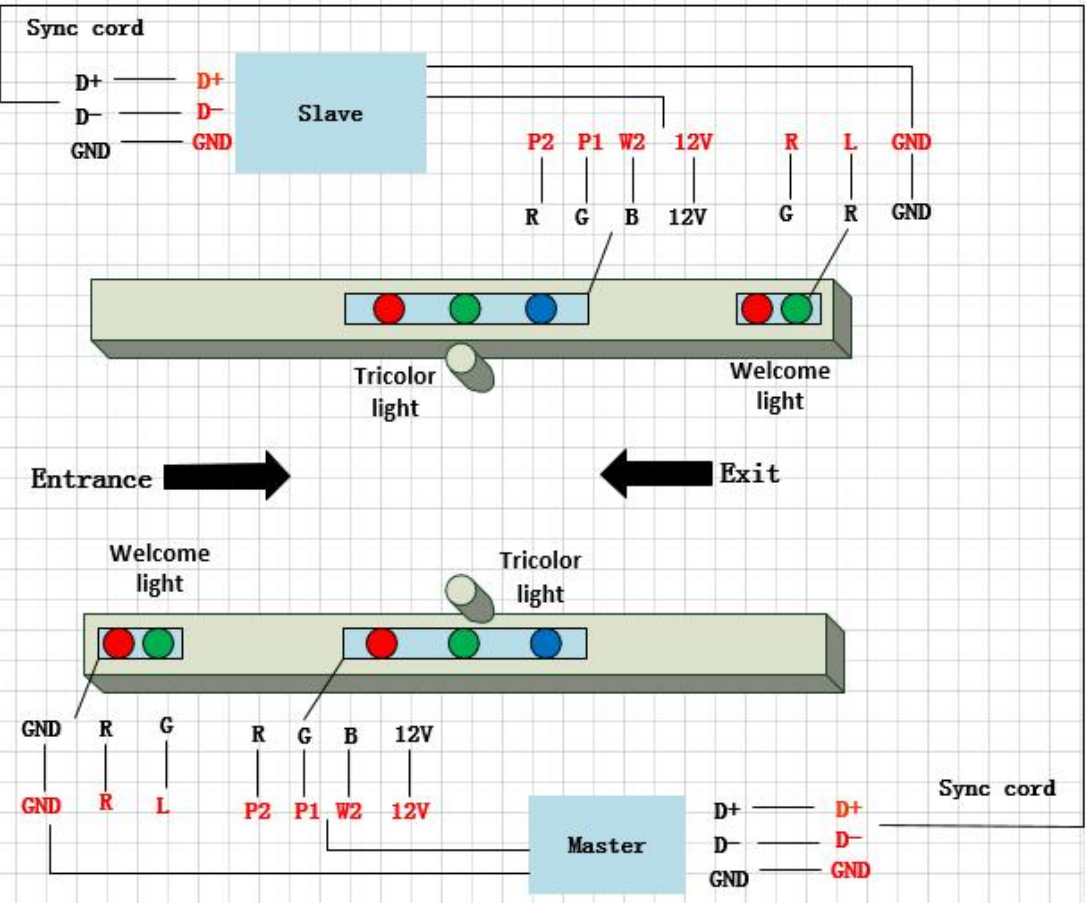

Pass lamp board + RGB tricolour light

(Set the parameter F46=2, F50=1)

Pass lights: red lights when idle; When swiping a card, the main direction is green and the opposite direction is red.

Tricolor light (common anode) : blue light when idle; When swiping the card, the green light is displayed; The red light is displayed when the alarm is raised.

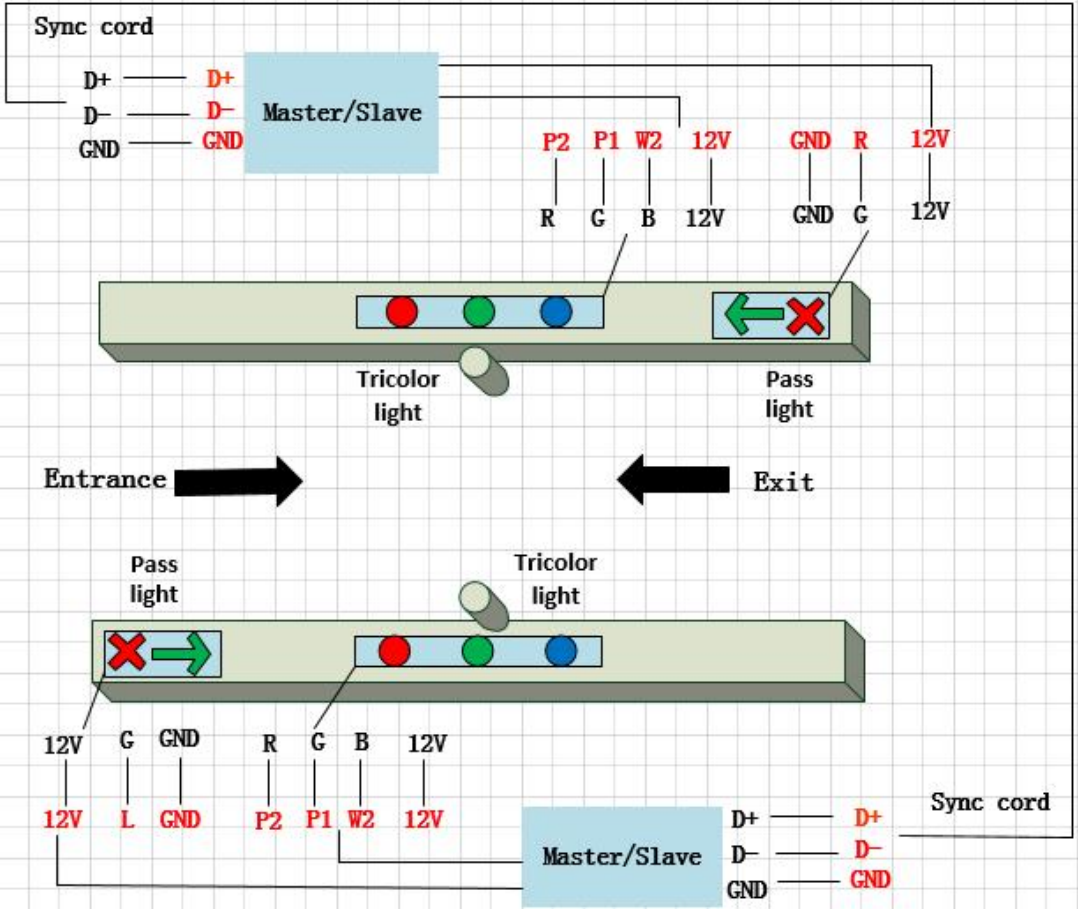

Pass light belt + RGB tricolour light

(Set the parameter F46=2, F50=1)

Traffic lights (common anode) : red lights are displayed when idle; When swiping a card, the main direction is green and the opposite direction is red.

Tricolor light (common anode) : blue light when idle; When swiping the card, the green light is displayed; The red light is displayed when the alarm is raised.

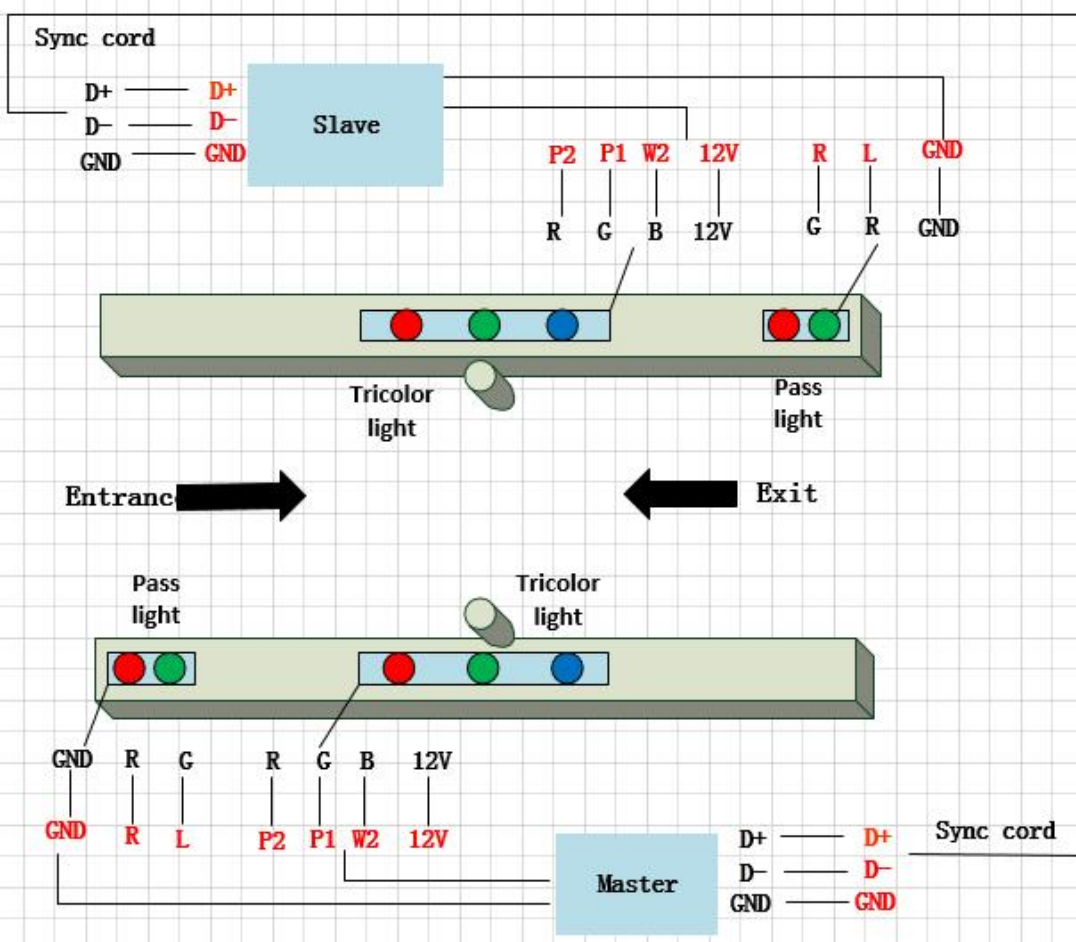

Standard RGB tricolour light

(Set the parameter F46=2)

Tricolor light (common anode) : blue light when idle; When swiping the card, the green light is displayed; The red light is displayed when the alarm is raised.

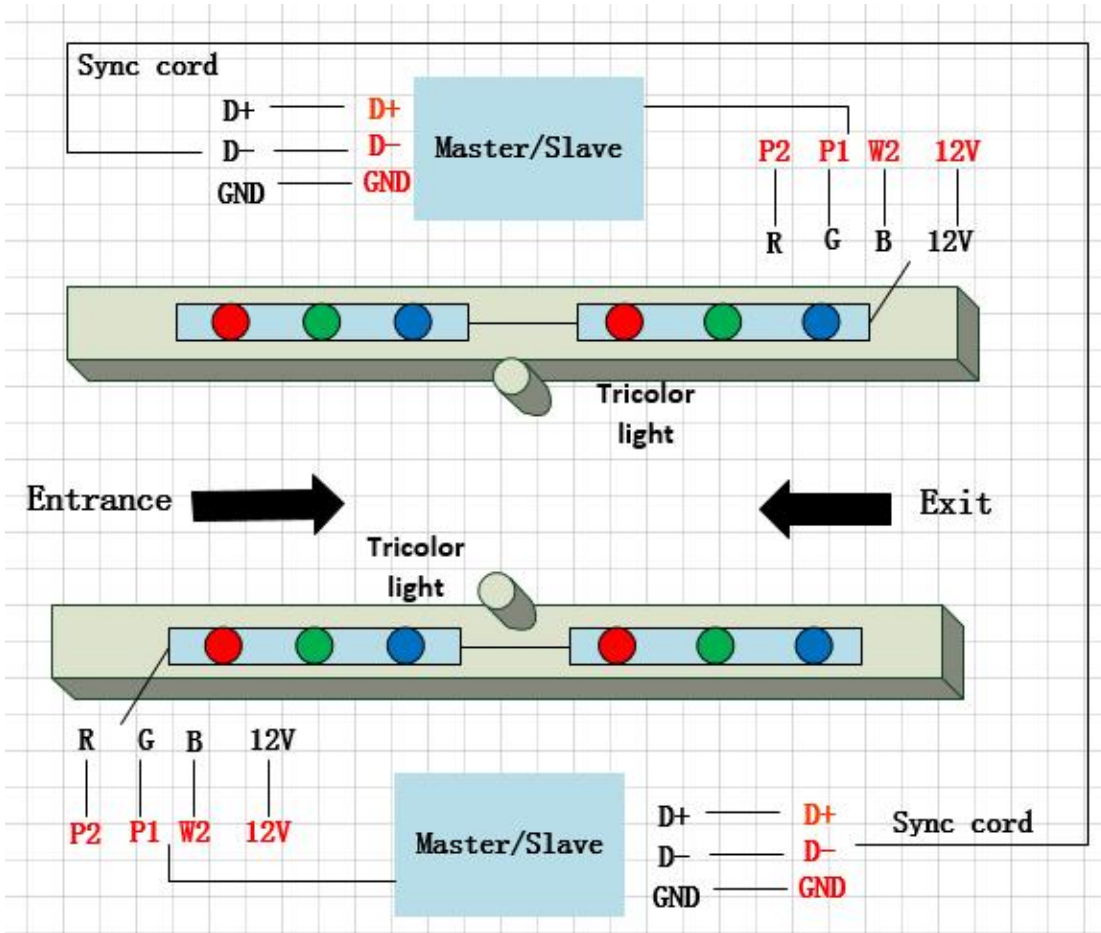

Dyadic indication RGB tricolour light

(Set the parameter F46=2)

Tricolor light (common anode) : blue light when idle; When swiping the card, the green light is displayed; The red light is displayed when the alarm is raised.

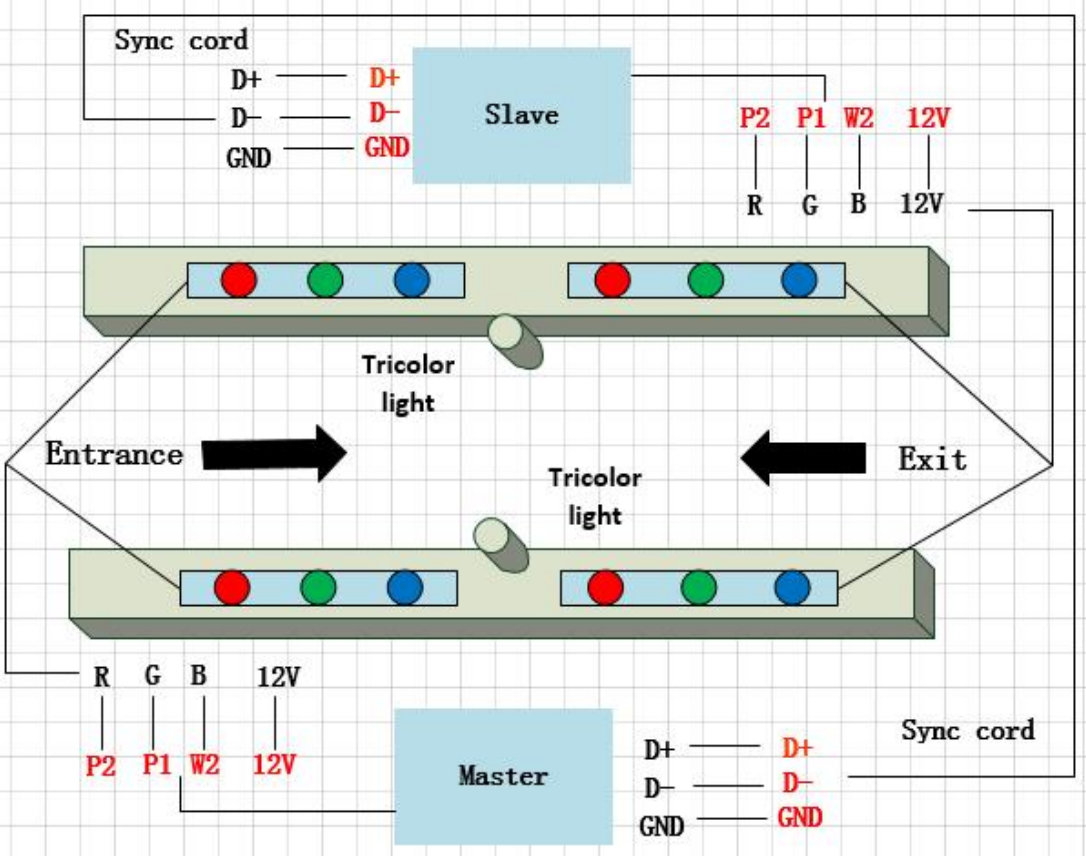

Note: Because the output port is limited, MBC2405 currently supports at most two kinds of light belts or light boards

Chapter 5– Safety attentions

- Do not strike the product with hard objects.
- Handle carefully when using to avoid strong collision with hard objects.
- The product must not be exposed to water or corrosive liquids.
- If smoke or odor is found in the product, disconnect the power immediately.
- If the product is abnormal, please contact the dealer in time. Do not attempt to repair it by yourself. If you do not contact the dealer, handle it without permission, and the company will not be responsible for any damage.

Chapter 6 – Transportation and storage

- Handle the product with care when handling it.
- During the transportation and storage of the product, care should be taken in a dry and free of corrosive or explosive gas in the surrounding air, and measures should be taken to prevent moisture, rain, sun, and corrosion

Thank you for your support, we are very happy to be your partner and provide you with our services. If you encounter any problems during the installation, you can contact your service manager at any time. We will serve you wholeheartedly, ENJOY!

----- KARSUN TEAM